



SPL (Hong Kong) Limited

Rm 2507, 25/F, Prosperity Centre, 25 Chong Yip St., Kwun Tong, Kln., HK.
Tel: 852-23426867 / 57 Fax: 852-23426847 Email: sales@spl-hk.com.hk
www.buzzer.com.hk ; www.transducer.com.hk ; www.connector.com.hk

Piezo Buzzer SPB47 series

DIMENSIONS

Date : 05 Jan., 2011

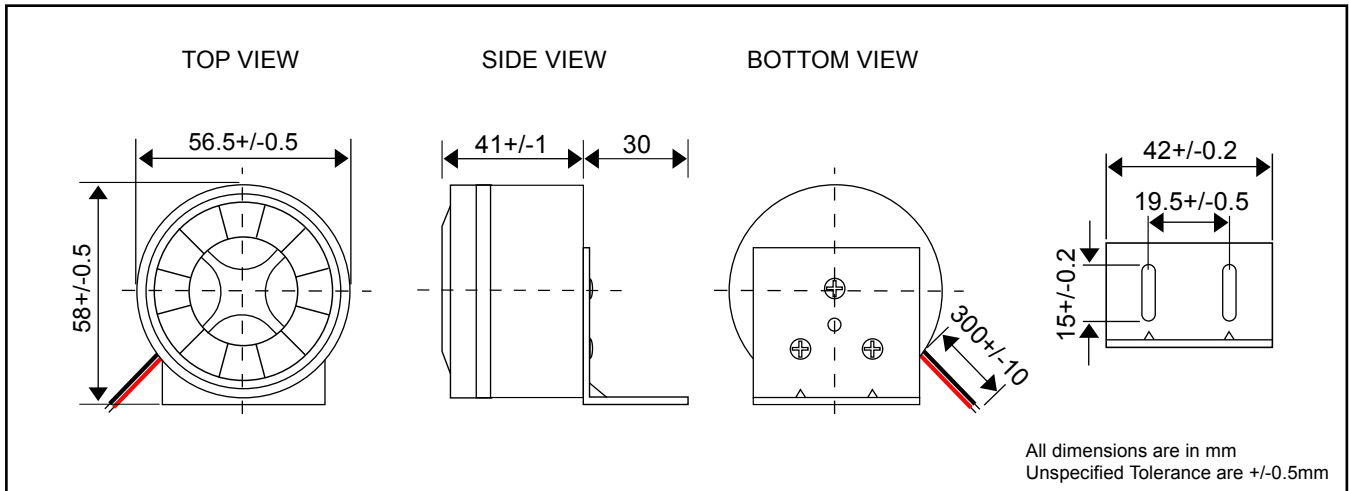

Ref. no. : PR011-3R

Remark : 110 x 165mm Plastic bag, 28 x 40mm label with barcode, A4 size specification



ELECTRICAL SPECIFICATIONS

Model No. (Preliminary)		PB47-Z337R
Operating Voltage	[VDC]	8 ~ 16
Rated Voltage	[VDC]	12
* Max. Rated Current	[mA]	250
* Min. Sound Output	[dBA /100cm]	100
* Frequency	[Hz]	2900 +/- 500
Tone Nature		Fast Pulse Sound
Operating Temperature	[°C]	-20 ~ +70
Storage Temperature	[°C]	-30 ~ +80
Terminal		AWG#22-UL1007 Wire
Housing Material		ABS
Colour		Black
Weight	[gm]	8